

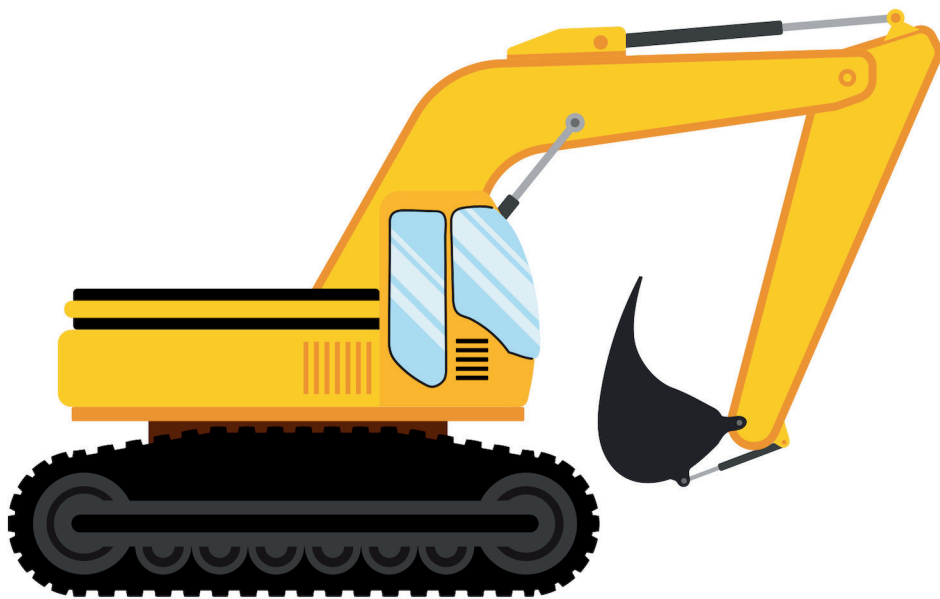

VACANCES SCOLAIRES

Le cahier d'activités

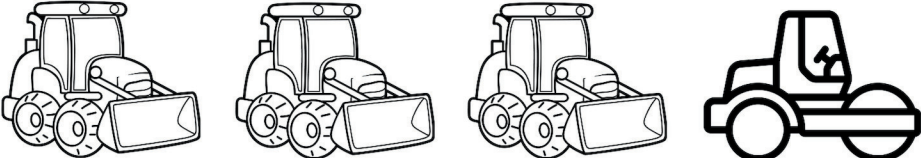
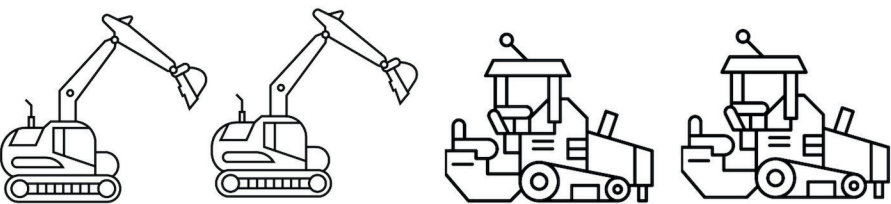
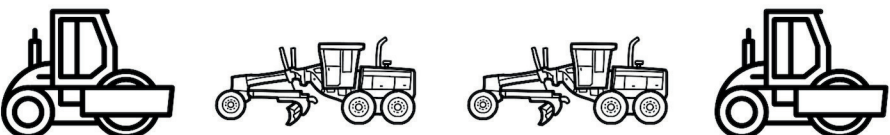

PRENOM _____

COLORIEZ, COUPEZ ET COLLEZ LES
ÉQUIPEMENTS CI-DESSOUS POUR
COMPLÉTER LES MOTIFS DE GAUCHE.

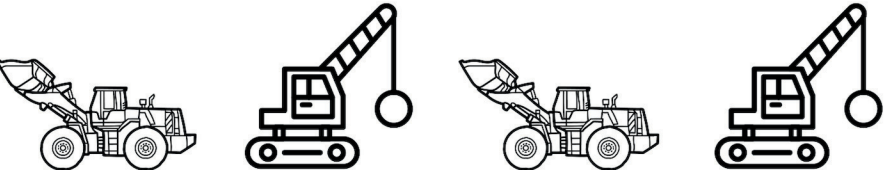
| | |
|--|--|
|  | |
|  | |
|  | |
|  | |
|  | |

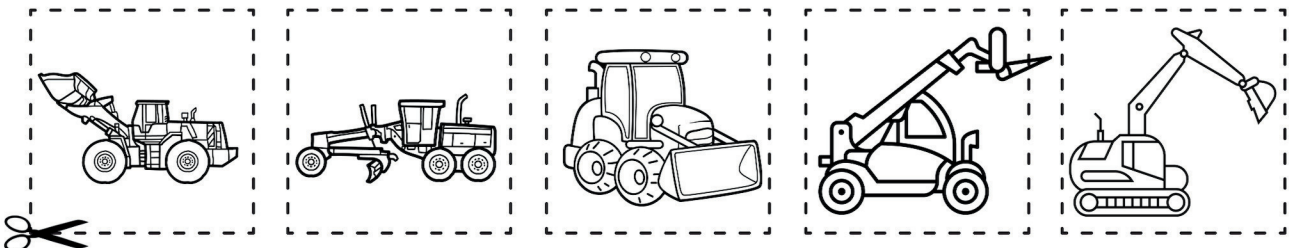

ENTRAÎNEZ-VOUS À ÉCRIRE L'ALPHABET À L'AIDE DE CES CONSTRUCTEURS.

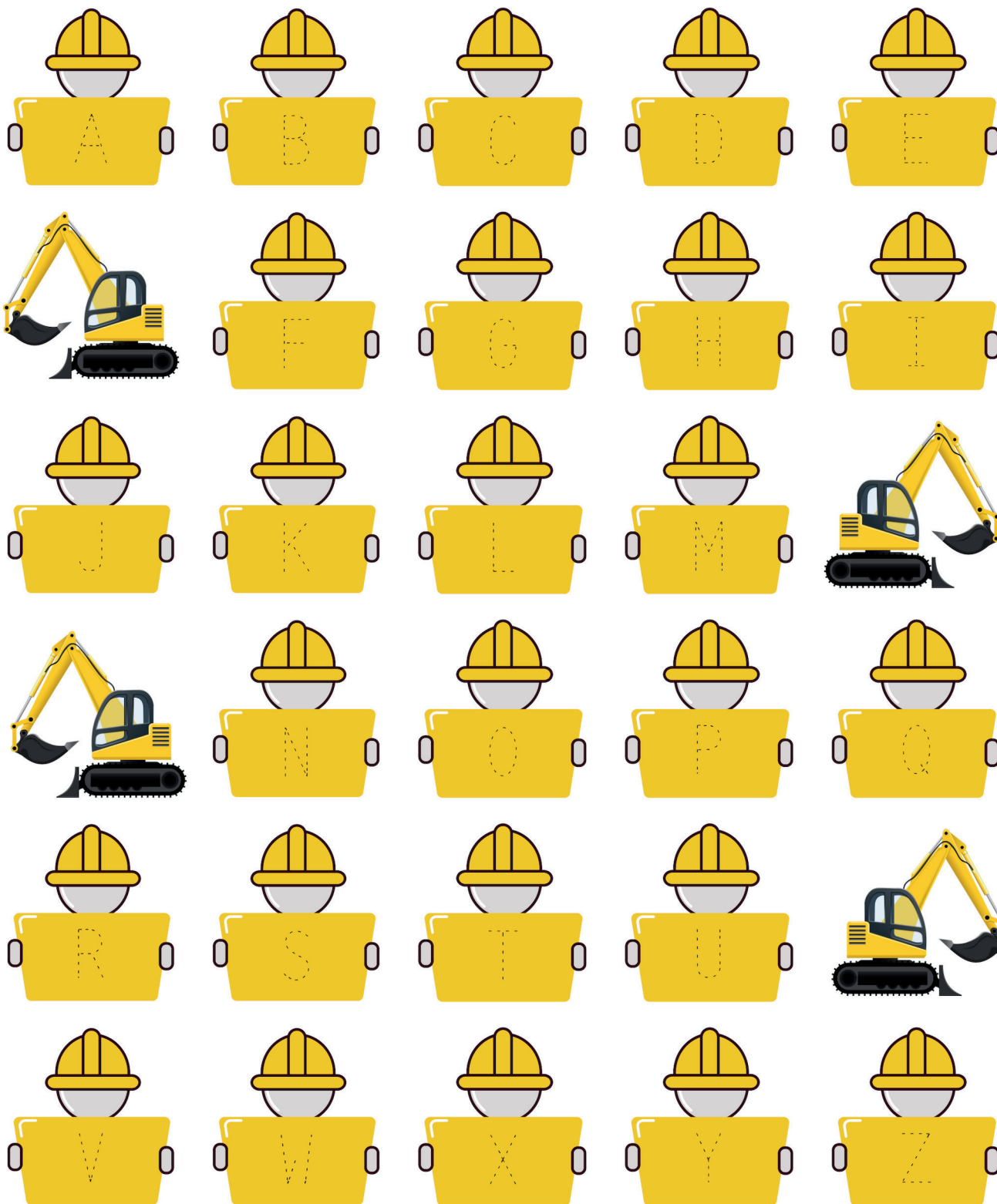

Pouvez-vous emmener Anna sur le chantier ?



COMMENCER

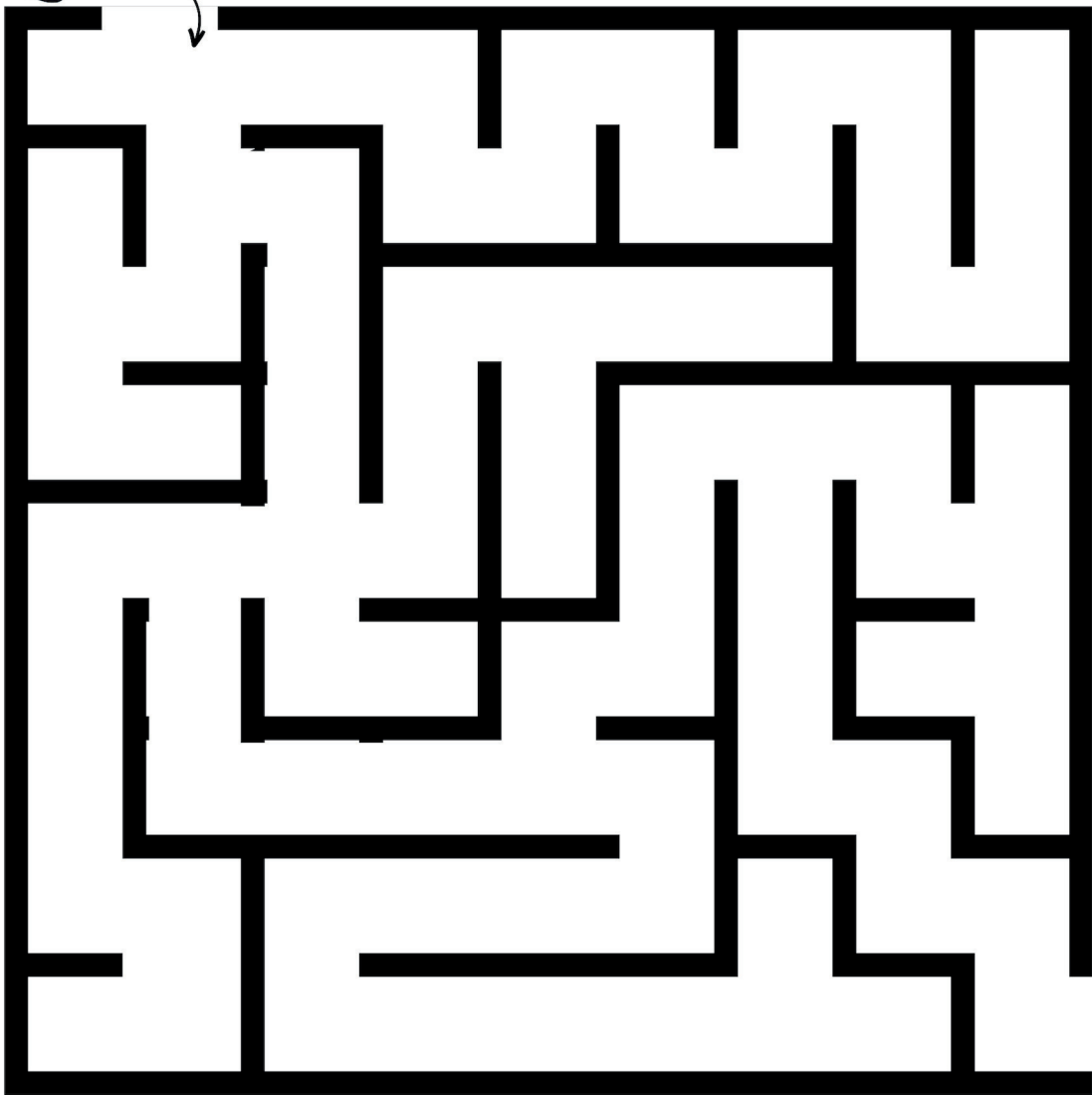

TRACEZ UNE LIGNE ET AIDEZ LES ENFANTS À SE RENDRE À LEUR ÉQUIPEMENT PRÉFÉRÉ !

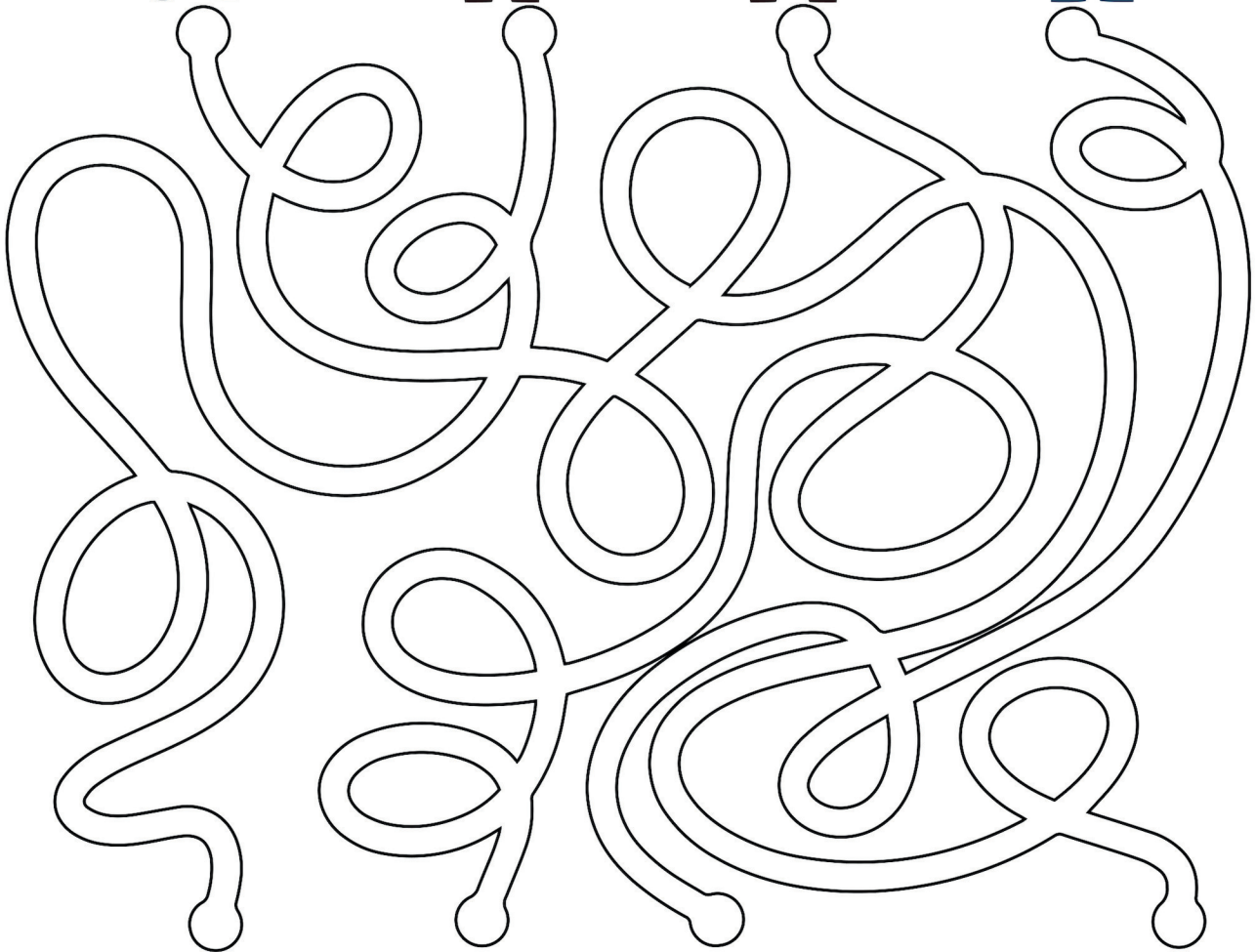



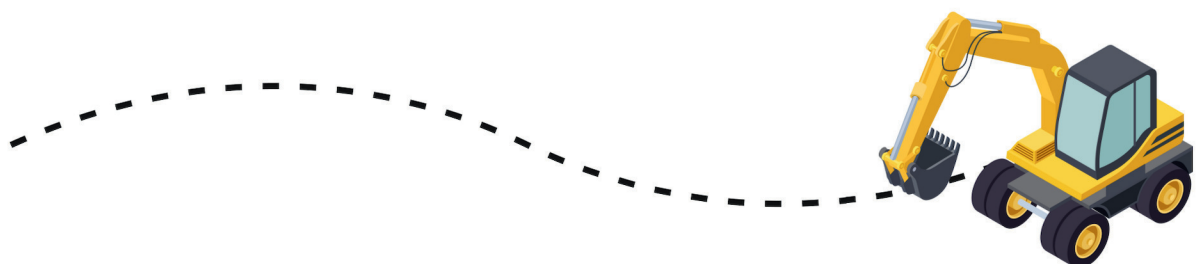
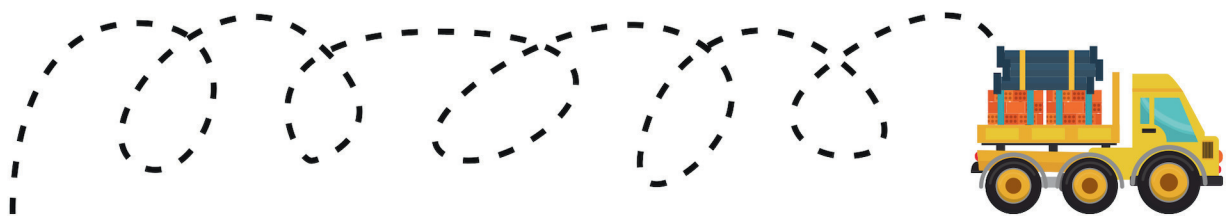
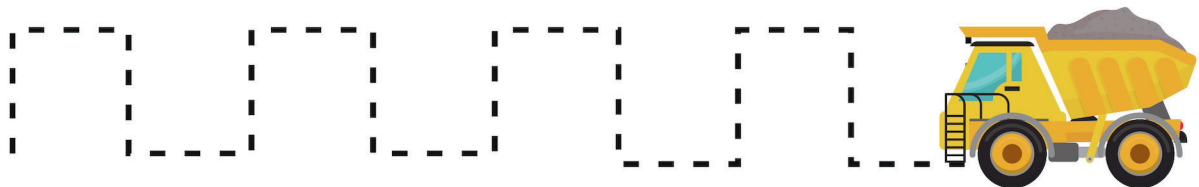





































TRACEZ LES LIGNES !



Pratique des nombres 1-20

ENTRAÎNEZ-VOUS À COMPTER. REMPLISSEZ
LES BLANCS AVEC LES CHIFFRES MANQUANTS.

| | | | |
|---|---|--|---|
|   1 |   |   3 |   |
|   |   6 |   7 |   |
|   |   10 |   |   |
|   13 |   |   |   16 |
|   |   18 |   |   20 |

FAITES DES ADDITIONS
EN MATHEMATIQUES !



$$\begin{array}{r} 3 \\ + 5 \\ \hline \end{array}$$

$$\begin{array}{r} 9 \\ + 6 \\ \hline \end{array}$$

$$\begin{array}{r} 7 \\ + 1 \\ \hline \end{array}$$

$$\begin{array}{r} 5 \\ + 7 \\ \hline \end{array}$$

$$\begin{array}{r} 2 \\ + 3 \\ \hline \end{array}$$

$$\begin{array}{r} 3 \\ + 3 \\ \hline \end{array}$$

$$\begin{array}{r} 4 \\ + 6 \\ \hline \end{array}$$

$$\begin{array}{r} 4 \\ + 5 \\ \hline \end{array}$$

$$\begin{array}{r} 1 \\ + 6 \\ \hline \end{array}$$

$$\begin{array}{r} 2 \\ + 2 \\ \hline \end{array}$$

$$\begin{array}{r} 3 \\ + 5 \\ \hline \end{array}$$

$$\begin{array}{r} 9 \\ + 4 \\ \hline \end{array}$$

$$\begin{array}{r} 9 \\ + 6 \\ \hline \end{array}$$

$$\begin{array}{r} 6 \\ + 6 \\ \hline \end{array}$$

$$\begin{array}{r} 8 \\ + 5 \\ \hline \end{array}$$

$$\begin{array}{r} 7 \\ + 5 \\ \hline \end{array}$$

$$\begin{array}{r} 0 \\ + 3 \\ \hline \end{array}$$

$$\begin{array}{r} 8 \\ + 4 \\ \hline \end{array}$$

$$\begin{array}{r} 5 \\ + 4 \\ \hline \end{array}$$

$$\begin{array}{r} 4 \\ + 6 \\ \hline \end{array}$$

$$\begin{array}{r} 1 \\ + 5 \\ \hline \end{array}$$

$$\begin{array}{r} 4 \\ + 5 \\ \hline \end{array}$$

$$\begin{array}{r} 9 \\ + 1 \\ \hline \end{array}$$

$$\begin{array}{r} 6 \\ + 7 \\ \hline \end{array}$$

$$\begin{array}{r} 1 \\ + 7 \\ \hline \end{array}$$

$$\begin{array}{r} 0 \\ + 5 \\ \hline \end{array}$$

$$\begin{array}{r} 8 \\ + 6 \\ \hline \end{array}$$

$$\begin{array}{r} 7 \\ + 6 \\ \hline \end{array}$$

$$\begin{array}{r} 4 \\ + 5 \\ \hline \end{array}$$

$$\begin{array}{r} 2 \\ + 6 \\ \hline \end{array}$$

Quelle heure est-il ?

ÉCRIVEZ LES HEURES INDIQUÉES SUR LES HORLOGES.

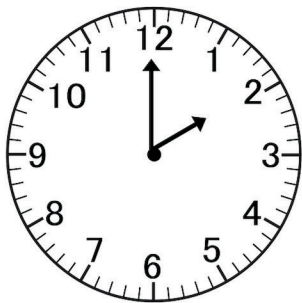

1. _____

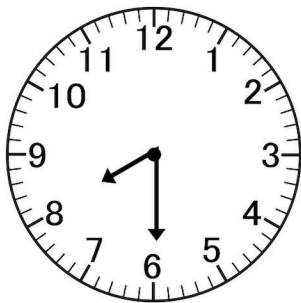

2. _____

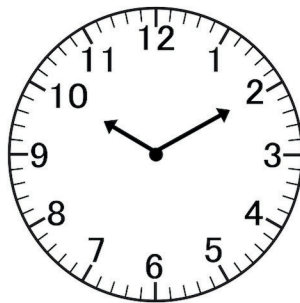

3. _____

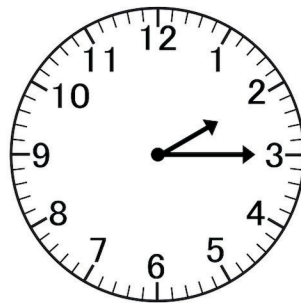

4. _____

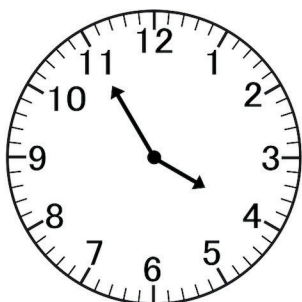

5. _____

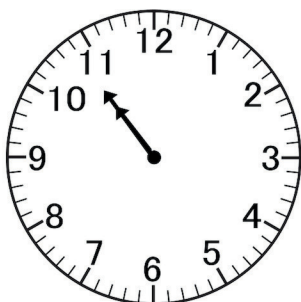

6. _____

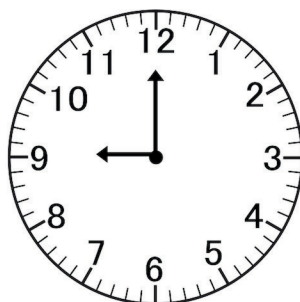

7. _____

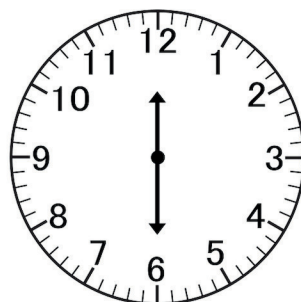

8. _____

DESSINEZ DES AIGUILLES SUR LES HORLOGES POUR INDiquer L'HEURE.

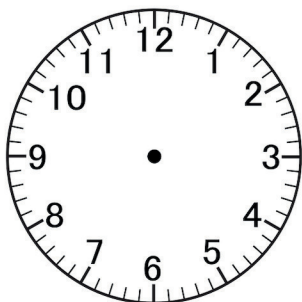

9. **9:25**

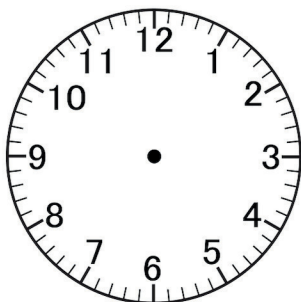

10. **6:30**

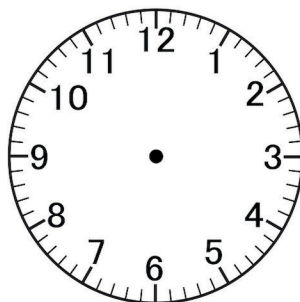

11. **12:05**

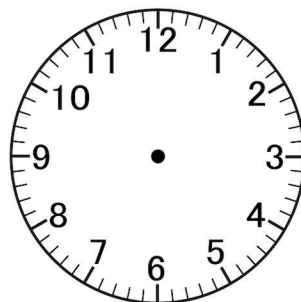

12. **4:35**

1. Reliez les points avec les chiffres de 1 à 20.
2. Coloriez l'image en couleurs vives.
3. Tracez le nom de l'équipement.

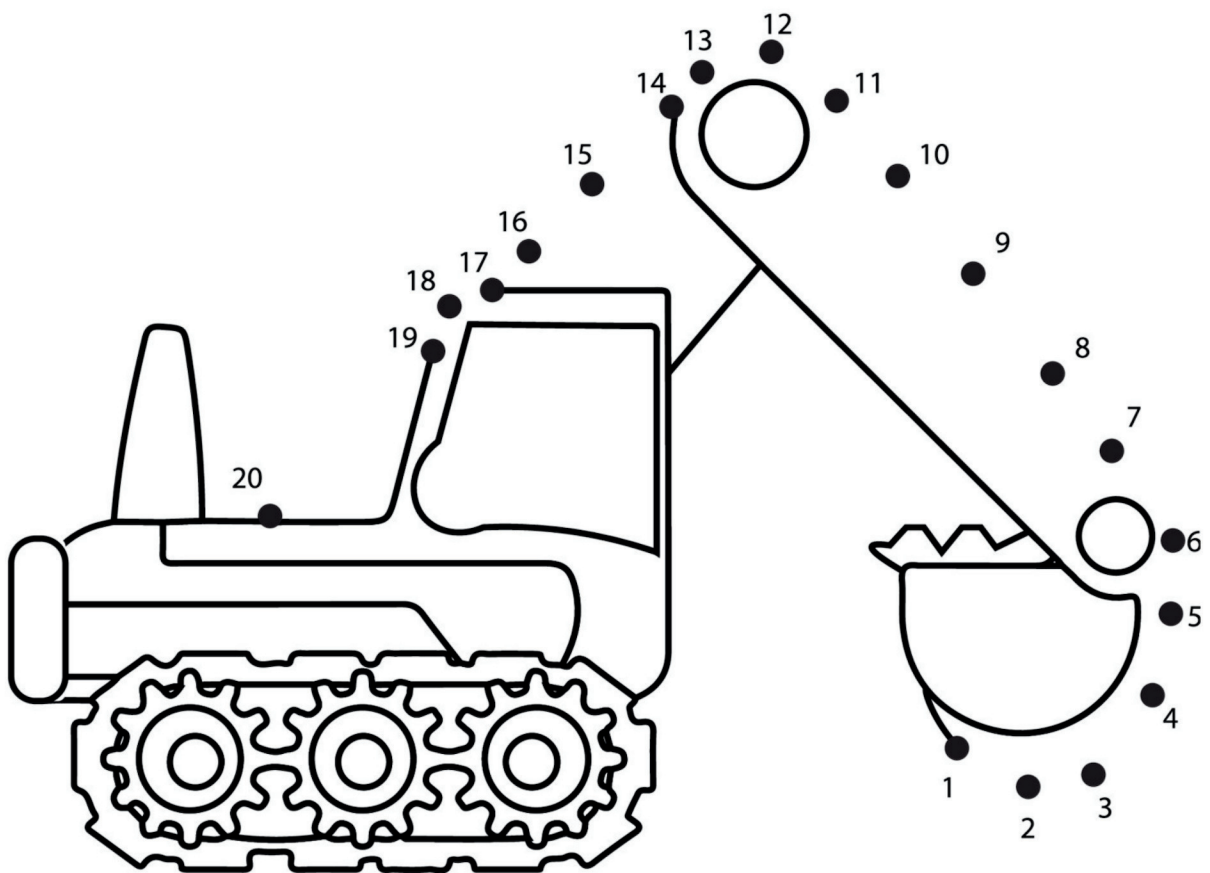

Pelle

1. Reliez les points avec les chiffres de 1 à 20.
2. Coloriez l'image en couleurs vives.
3. Tracez le nom de l'équipement.

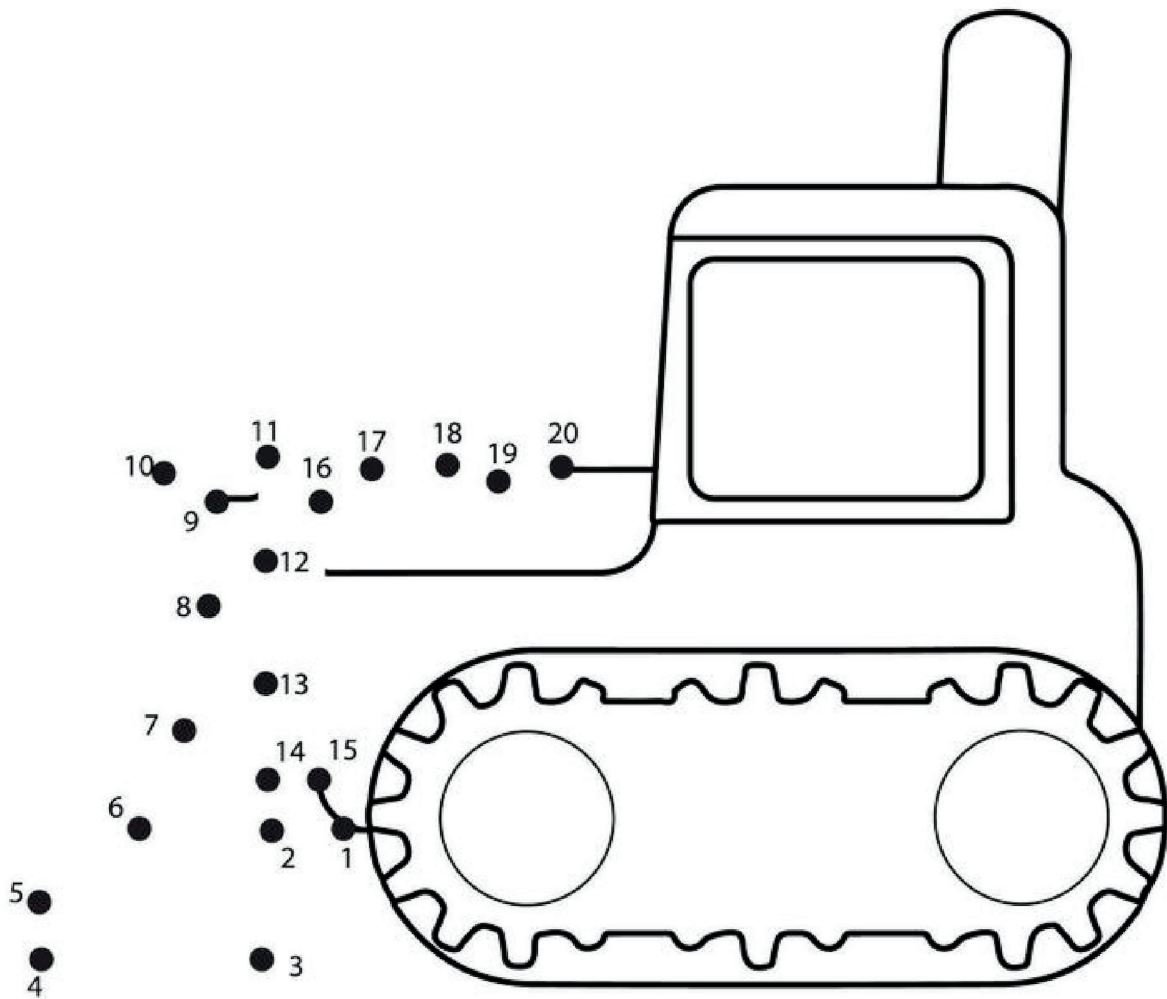

Tracteur

1. Reliez les points avec les chiffres de 1 à 20.
2. Coloriez l'image en couleurs vives.
3. Tracez le nom de l'équipement.

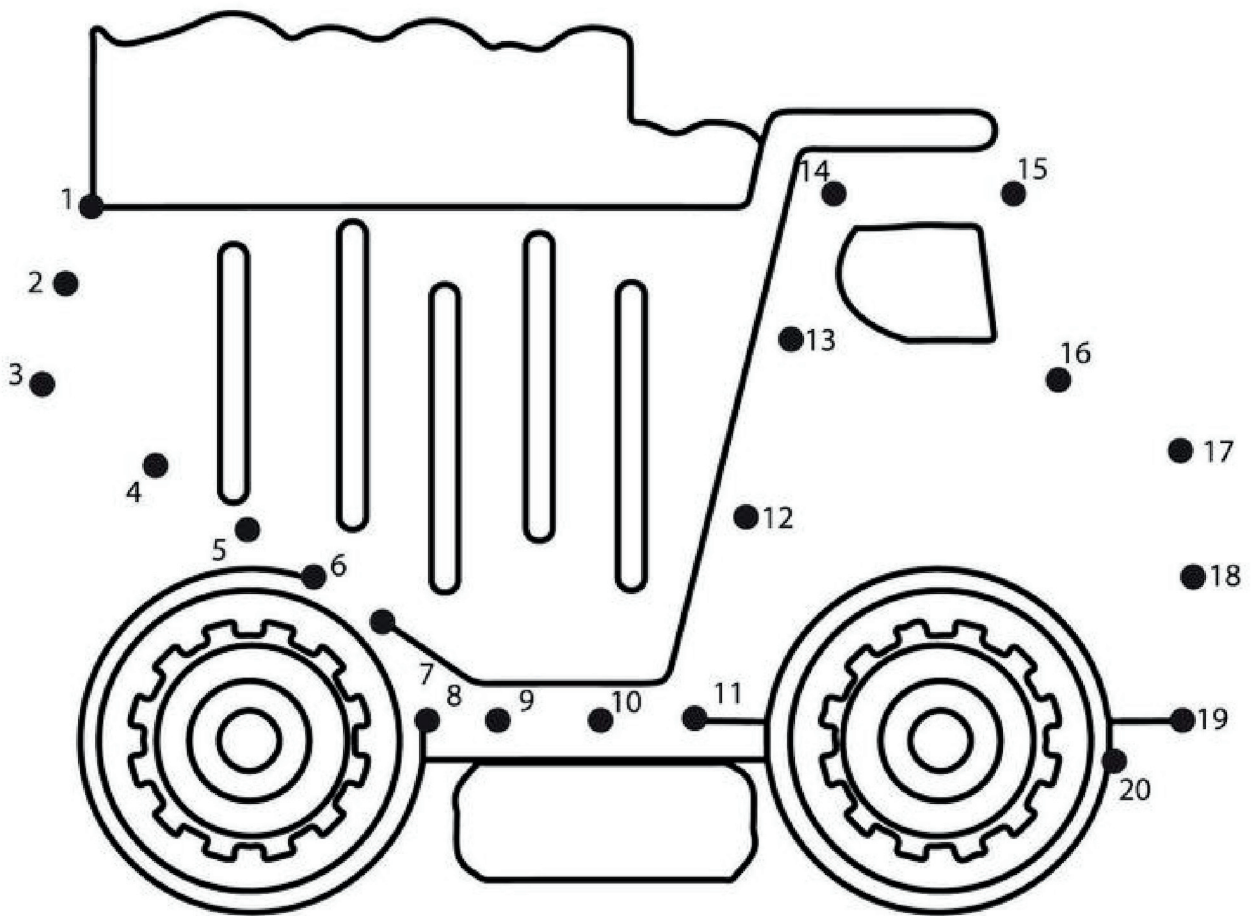

Tombereau

BONNES VACANCES !

